



Rental Grade Unit MMG55 - 50kW John Deere

Generator-Mounted
Voltage Selector Switch

Sound Attenuated, Rust-Free
Aluminum Enclosure

Single-Point Lifting

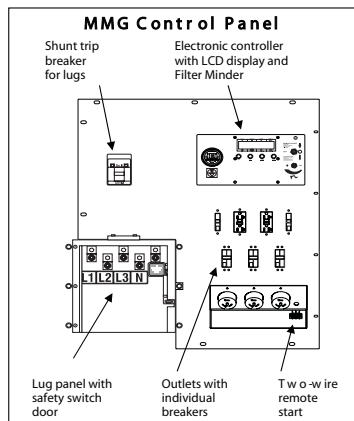

Easy Access to
Services Ports

Lockable
External Fuel Fill

24 Hour Fuel
Tank in Skid

TOUGH

- ALUMINUM ENCLOSURE
- LOCKABLE ENCLOSURE
- STEEL SKID AND TRAILER
- DURABLE POWDER COAT FINISH

RELIABLE

- SOPHISTICATED MICROPROCESSOR
- VOLTAGE REGULATION WITHIN 1%
- 24 HOUR FULL LOAD RUN TIME
- AIR FILTER CONDITION INDICATOR
- 1 YEAR 1,000 HOUR WARRANTY

EASY TO USE

- VOLTAGE SELECTOR SWITCH
- LUGS AND LUG BOX SAFETY SWITCH
- MULTIPLE CONVENIENCE OUTLETS
- EXTERNAL EMERGENCY STOP SWITCH
- EXTERNAL, LOCKABLE FUEL CAP
- AUTOMATIC REMOTE START
- ENHANCED MOTOR
- STARTING OPTION AVAILABLE

Rental Grade Unit

MMG55 - 50kW John Deere

Output	
3 Phase - Standby (kW/kVa)	50 / 62
Amps (480/208 V)	72 / 172
3 Phase - Prime (kW/kVa)	43 / 53
Amps (480/208 V)	64 / 149
1 Phase - Standby (kW/kVa)	45 / 45
Amps (240 V)	188
1 Phase - Prime (kW/kVa)	41 / 41
Amps	171
AC Voltage - 1 Phase	120, 139, 208, 220, 240, 277
AC Voltage - 3 Phase	208, 220, 440, 480
Frequency Hz.	60
Power Factor	1.0 (1 Phase) / .8 (3 Phase)
Generator (Brand/Type/Insulation)	Marathon / Brushless / H
Sound (dB(A) 23 Feet @ Prime)	68
Size & Weight	
Skid Mounted (L x Wx H)	95 x 35 x 55.5
Dry Weight lb. (kg.)	2345 (1065)
Operating Weight lb. (kg.)	3180 (1445)
Trailer Mounted (L x W x H) (in.)	143 x 57 x 72
Dry Weight lb. (kg.)	2860 (1300)
Operating Weight lb. (kg.)	3700 (1680)
Engine	
Brand	John Deere
Aspiration	Turbo
HP (Prime @ 1800 rpm) (kWm)	72 (54)
Displacement C.I.D. (l.)	186 (3.0)
Cylinders	5
Speed (rpm)	1800
Fuel Consumed (Prime gal. (l.)/h)	4.0 (15.1)
Battery (12 volt)	1 - 12V/1000 CCA
Capacities	
Fuel Tank gal.(l.)	116 (440)
Approximate Run Time (hrs.)	26
Coolant qt. (l.)	17.5 (16.5)
Oil qt. (l.)	9 (8.5)
AC Distribution	
Main Breaker	225
Voltage Selection	3 Position Switch (Locable)
Voltage Regulation	+/-1%
120V - 20 Amp GFI Duplex	2
240V - 30 Amp Twist Lock	NA
240V - 50 Amp Twist Lock	2
Trailer	
Number of Axles & Capacity (lbs.)	1 (5000)
Tire Size (in.)	15
Brakes	Surge / Electric
Hitch	2" Ball / 3" Ring